

SONICA® 1200



1,9
LITRES

General characteristics

Ultrasonic Cleaning is a safe and efficient modern procedure, which ensures perfect cleaning within the shortest time possible. It has many advantages over ordinary cleaning methods. Ultrasonics can remove even the most tenacious deposits from parts which would be difficult to reach by hand, it also reduces the risk of injury or infection which may occur during manual cleaning



Tank Dimensions

Length	150 mm
Breadth	140 mm
Depth	100 mm
Capacity	1,9 litres

External Dimensions

Length	180 mm
Breadth	165 mm
Height	210 mm
Weight	about 1,8 kg

Constructive Materials

External	Steel AISI 304
Internal	Steel AISI 304

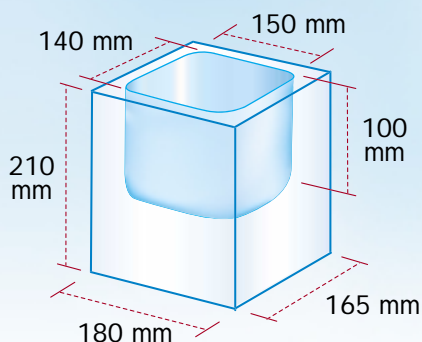

CE EMC 89/336/CEE (EN 55011B)
LV 73/23/CEE (EN 61010-1)
MD 93/42/CEE Medical Devices

1,9 LITRES SONICA® 1200

Technical Data

Main line voltage	230/240 V~50/60Hz
Main input power/consumption	80 W
Peak HF ultrasound power	160 W
US frequency	45 kHz ± 5%
Liquid drain	No
Transducers	1

Environmental conditions: Temperature

Rel. Hum. 80% up to 31°C. with linear decrease up to 50% at 40°C

Installation category: Class II according to EN 61010

Notes for use as "Medical Devices":

Denomination: Ultrasonic Cleaning Device

UMDNS-nomenclature (ECRI) 14-263

Field of application: cleaning and disinfection of surgical and dental instruments

Classification ((Medical Devices Directive 93/42/EEC, appendix IX):
Class I, Non Active MD, Non Invasive MD, Non Implantable MD

AVAILABLE SERIES



Version M The simplest version in the SONICA® range is equipped with a timer which can be set for to 15 minutes. It can also be set to manual operation..